



LITHIUM BATTERY PACK

ESS-48V 100Ah

FEATURES

Lithium Iron Phosphate (LiFePO4): the Safest Lithium Technology.
 Integrated Battery Management System(BMS).
 Bluetooth/RS485/RS232/SMBus/CANBus (Optional).
 SOC LED/LCD Indicator(Optional).

PERFORMANCE

Long Cycle Life>6000cycles @80% DOD.
 High Density, High Discharge Current, High Temperature Range.
 Low Weight, Free Maintenance.
 Fast Charging.
 Environment Friendly.

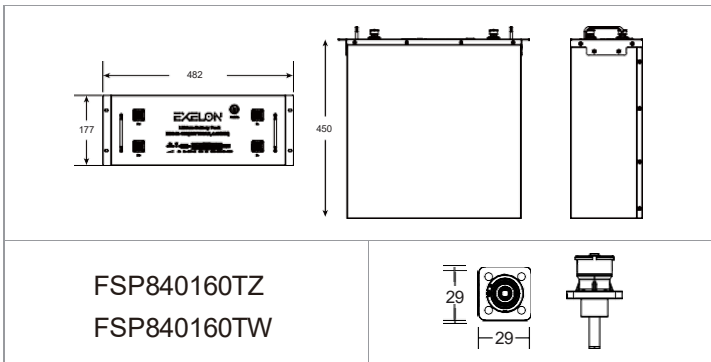

CHARACTERISTICS

Item	Specifications
Nominal Voltage	48V
Rated Capacity	100Ah
Energy	4800Wh
Resistance	≤30mΩ
Efficiency	99%
Cycle Life	>6000cycles @ 80% DOD
Self Discharge	2% per Month

Dimension(L x W x H)	482 x 450 x 177 mm
	18.98 x 17.71 x 6.97"
Weight	43.5kg(95.9lbs)
Terminal Type	FSP840160TZ/TW
Battery Housing	Metal
Housing Protection	IP56
Cell Type-Chemistry	LiFePO4 Battery Cell
SoC Display	LED/LCD Indicator

Charge Method	CC-CV
Charge Voltage	54~55.5V
Recommended Float Voltage	51.75V
Recommended Charge Current	50A
Maximum Charge Current	100A
BMS Charge Cut-off Voltage	58.5V

Discharge Temperature	-20 to 60°C (-4 to 140°F)
Charge Temperature	0 to 45°C (32 to 113°F)
Storage Temperature	0 to 60°C(32 to 140°F)
BMS High Temperature Cut-off	80°C(176°F)

Continuous Discharge Current	100A
Pulse Discharge Current	300A(<3 seconds)
Recommended Volt. Disconnect	37.5V
BMS Discharge Cut-off Voltage	30V
Reconnect Voltage	34.5V
Short Circuit Protection	200~600 us

CHARACTERISTICS

- + Military Power Supply
- + Solar Energy Storage System
- + Solar Street LED Lightings
- + Industrial Robotics & Handling Equipment
- + Aerial Work Platform

DISCHARGE CAPACITY at VARIOUS TEMPERATURES
DISCHARGE @0.5C, 25 °C

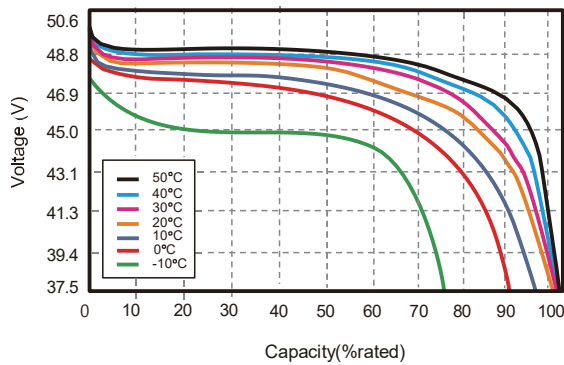

CHARGING CHARACTERISTICS @0.5C, 25 C

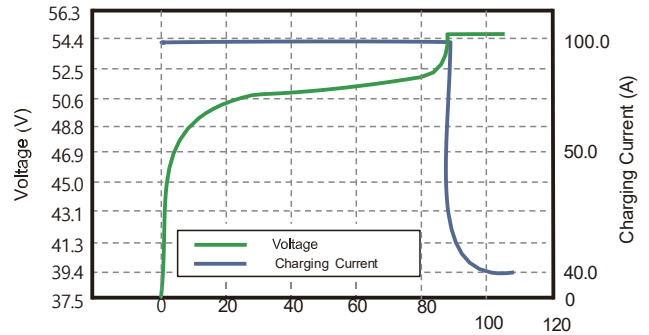

CYCLE LIFE vs.DEPTH OF DISCHARGE(DOD)
DISCHARGE@0.5C, 25 °C

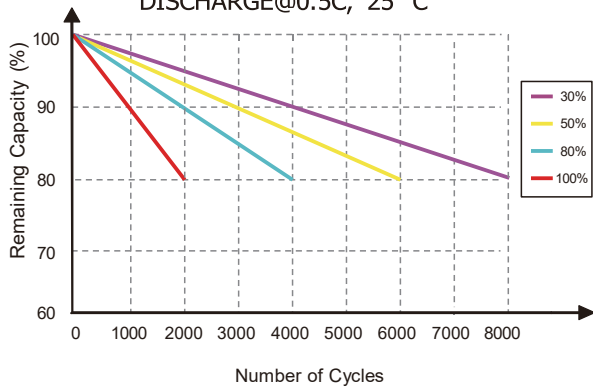

STATE OF CHARGE CURVE @0.5C, 25 C

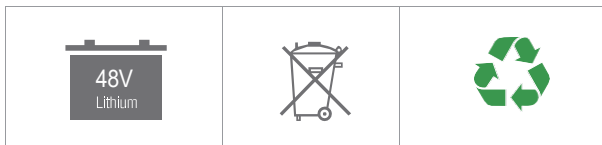
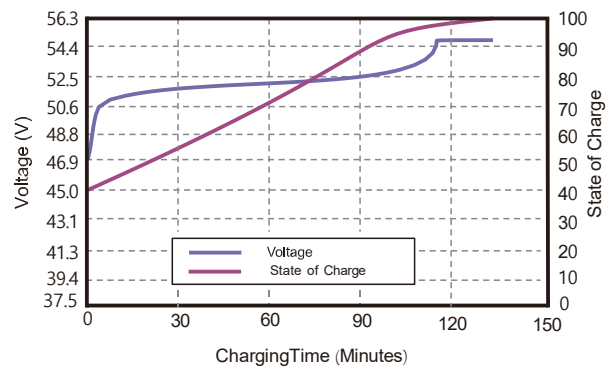

www.exelone.com

NOTE: Do Not Mix With Sealed Lead Acid Batteries When Recycling.

